

4-WAY FULLY-PORTED STEM VALVES



4-WAY FULLY-PORTED STEM VALVES

4-way fully-ported valves have two inlets, two

outlets and one exhaust port. When the stem is in one position air flows from one inlet to its outlet while the other inlet is blocked. Moving the stem to the opposite position reverses this action. This may be defined as two 3-way valves, one Normally Closed and one Normally Open operating simultaneously. 4-way fully ported stem valves may either be spring return or double acting. A double acting stem must be moved from one position to the other, a spring return stem will move to the opposite position when released.

4-Way Fully-Ported Valves

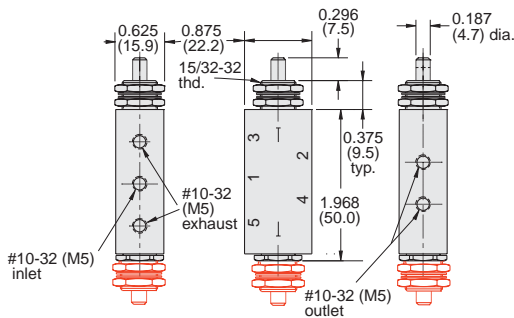
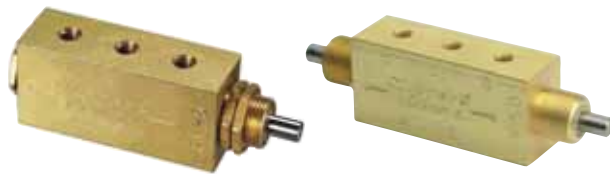

Medium: Air or Oil

Air Flow: 6.0 SCFM @ 50 psig; 10 SCFM @ 100 psig;
240 l/min @ 6 bar

Force For Full Stem Travel: FV-5 & FV-5-M5 - 4 1/2 lb. nominal;
FV-5D & FV-5D-M5 - 1 1/2 lb. nominal

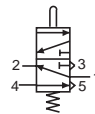

4-Way Fully-Ported Valves

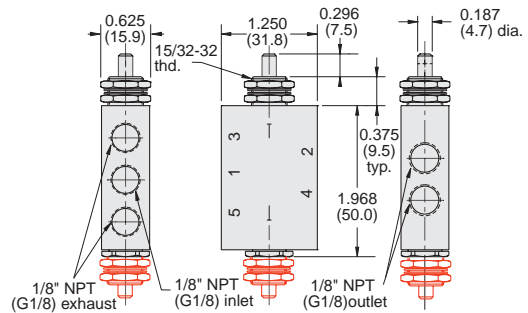
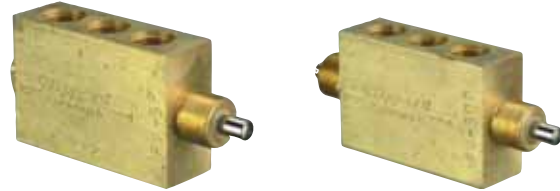

Medium: Air or Oil

Air Flow: 6.5 SCFM @ 50 psig; 10.5 SCFM @ 100 psig;
250 l/min @ 6 bar

Force For Full Stem Travel: FV-5P & FV-5-MG - 4 1/2 lb. nominal;
FV-5DP & FV-5D-MG - 1 1/2 lb. nominal

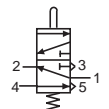

Part No. Description

- FV-5 Plunger Actuated Spring Return Valve, #10-32
- FV-5-M5 . . Plunger Actuated Spring Return Valve, M5
- FV-5D 2 Position Double Plunger Valve, #10-32
- FV-5D-M5 . . 2 Position Double Plunger Valve, M5

Part No. Description

- FV-5P Plunger Actuated Spring Return Valve, 1/8" NPT
- FV-5-MG Plunger Actuated Spring Return Valve, G1/8
- FV-5DP 2 Position Double Plunger Valve, 1/8" NPT
- FV-5D-MG . . . 2 Position Double Plunger Valve, G1/8

Flow Paths for "FTV & FV" Series

Solid lines indicate flow paths with toggle or stem in one direction. Dotted lines indicate flow paths when the toggle or stem are shifted.

